

Kingspan

Installation & Maintenance Instructions for an unvented hot water cylinder with internal thermal expansion



Kingspan Water & Energy
48 Thornes Lane
Wakefield
West Yorkshire
WF1 5RR
0345 260 0258
hotwater@kingspan.com
kingspancylinders.com

Part No: 026447 - AUG 2023 v3



CONTENTS

3	Your cylinder and its components
3-4	Preparing to install the cylinder
4-7	Installation instructions
8-9	Product connections
10	Product technical specification
11-13	Schematic wiring diagrams
14	Pre-plumbed cylinder installation
15	Commissioning and decommissioning
15-16	Homeowner / User instructions
16-17	Servicing
17	Fault-finding
18-19	Benchmark Commissioning Checklist
20	Service Record
21-22	Guarantee
23-24	Product registration

See insert sheet for product-specific technical performance, specification details and lists of spare parts and approvals.



Benchmark places responsibilities on both the manufacturer and installer. The purpose is to ensure that customers are provided with the correct equipment for their needs, that the equipment is installed, commissioned and serviced in accordance with the manufacturer's instructions by competent persons and that it meets the requirements of the appropriate Building Regulations. The Benchmark Checklist can be used to demonstrate compliance with Building Regulations and should be provided to the customer for future reference.

Installers are required to carry out installation, commissioning and servicing work in accordance with the Benchmark Code of Practice which is available from the Heating and Hotwater Industry Council who manage and promote the Scheme. Visit www.benchmark.org.uk for more information.

INTRODUCTION

For over 90 years, Kingspan's unvented hot water cylinders have continued to meet the evolving and demanding hot water needs of homes in the UK and Ireland.

When installed and maintained in accordance with this manual, Kingspan cylinders will reliably store and generate hot water for years to come. This manual details how to prepare, install, commission, service, operate and decommission unvented heat pump hot water cylinders with a separate external thermal expansion vessel and buffer tanks.

As well as comprehensive instructions for installers, the manual provides guidance and guarantee information for homeowners.



Kingspan are Charter Members of the Hot Water Association and undertake to meet the requirements of the Charter Scheme:

- To supply fit for purpose products clearly and honestly described
- To supply products that meet or exceed appropriate standards and building and water regulations
- To provide pre and post technical support
- To provide a clear and concise warranty details to customers.

For further details on the Charter, please visit www.hotwater.org.uk/hwa-charter

IMPORTANT NOTE TO THE INSTALLER



Read these instructions before commencing installation. Unvented cylinders are a controlled service as defined in the latest edition of the building regulations and should only be fitted by a competent person.

You must ensure the installation complies with the current Building Regulations and or Technical Standards Documents for England, Scotland, Wales, N Ireland or Ireland.

After installation the Benchmark Commissioning Checklist on page 19 must be completed and left, with these instructions, with the householder for future reference.

IMPORTANT NOTE TO THE CYLINDER OWNER



Please ensure that the installer has fully completed the Benchmark Commissioning Checklist on page 19 of this installation manual. You will need this information should you need to make a claim against your product guarantee in the future.

This product requires servicing every 12 months and the Service Record must be maintained to protect your 25-year guarantee.

Please note all images are for illustrative purposes only and specific products will vary for each product line.



We take every care to ensure that the information in this document is accurate at the point of publication. Specification may vary (within a small parameter) due to manufacturing process variations or environmental conditions. All images are for illustration purposes only and should not be taken as binding. The actual product may vary, and specification/dimensions/colour/other attributes may differ.

To ensure you are viewing the most recent and accurate product information, please scan the QR code above or visit this link: <https://kingspan.com/content/dam/kingspan/kwe/products/tribune-xe-cylinders/kingspan-026447-manual-internal-expansion-en-gb.pdf>

©Kingspan and the Lion Device are Registered Trademarks of the Kingspan Group plc in the UK, Ireland and other countries. All rights reserved. Registered in Country No.NI017631. Registered Office: 180 Gifford Road, Portadown, Co. Armagh, BT63 5LF. VAT GB412 5124 03

YOUR CYLINDER AND ITS COMPONENTS

TABLE OF COMPONENTS All cylinders are supplied with the necessary fittings, safety and control devices needed to connect to the cold water mains. All have been pre-adjusted. High quality controls have been selected to combine high flow rate performance with minimum pressure drop. See insert sheet for a list of spare parts. Direct Models (Electric) Indirect Models (Single Coil) Indirect Solar Models (Twin Coil)	Inlet Control set	Temp & Pressure relief valve	Anti Splash Tundish	Titanium Immersion Heater	Two Port Valve	Integrated Dual Thermostat	Single High Limit Stat	Sensor pocket retaining bungs	Robo-kit including Heating Expansion Vessel	Programmable Room Thermostat	Two Channel Programmable Room Thermostat with DHW Control	Circulating Pump	Installation & Maintenance Instructions
Indirect Pre-Plumb Models – 1 Zone	●	●	●	●	●	●			●	●		●	●
Indirect Pre-Plumb Models – 2 Zone	●	●	●	●	●	●			●	●	●	●	●
System Fit Indirect Pre-Plumb Models – 1 & 2 Zone	●	●	●	●	●	●			●	●			●
Solar Indirect Pre-Plumb Models – 1 Zone	●	●	●	●	●	●	●	●	●	●		●	●
Solar Indirect Pre-Plumb Models – 2 Zone	●	●	●	●	●	●	●	●	●	●	●	●	●
Indirect Models	●	●	●	●	●	●							●
Direct Models (Electric)	●	●	●	●									●
Solar Indirect Models	●	●	●	●	●	●	●	●					●

PREPARING TO INSTALL THE CYLINDER

STORAGE PRIOR TO INSTALLATION

The unvented cylinder should be stored in its original packaging in an upright position in an area free from excessive damp.

HANDLING PRODUCT

The unvented cylinder should be carried upright where possible. Assessments of risks for carrying the cylinder should be conducted. Use more than 1 person for carrying where appropriate. Always follow latest guide lines for lifting techniques, to avoid injury and damage to the product.

WATER SUPPLY

The unvented cylinder operates at 3.0 bar (controlled by the inlet control set) and is capable of delivering over 50 litres per minute. The high quality inlet control set has been designed to make the most of the flow rates available, however the performance of any unvented system is only as good as the mains water supply. The maximum possible water demand should be assessed, taking into consideration that both hot and cold services are supplied simultaneously from the mains. The water supply should be checked to ensure it can meet these requirements. If necessary, consult the local water company regarding the likely pressure and flow rate availability.

If measuring the water pressure, note that a high static (no flow) mains pressure is no guarantee of good flow availability. In a domestic installation 1 bar and 25 l/min. should be regarded as the minimum. The maximum mains pressure that the inlet control set can accept is 12 bar. Consideration should be given to upgrading existing ½" (15mm) cold mains pipework to a larger size if the recommended minimum pressure/flow rate is not being achieved.

ELECTRIC SUPPLY

The unvented cylinder requires 240 Volt electrical supply for the immersion elements. The electrical supply to each immersion heater must be fused at 13A via a double pole isolating switch to BS 60335. The cable must be at least 2.5mm² heat resistant (85°C HOFr) sheathed flex complying to BS EN 50525-1.

UNPACKING THE UNIT

The unvented cylinder comes complete with the fittings required to complete the installation. See table of component above.

SITING THE UNIT

The unvented cylinder can supply outlets above it or at some distance from it. Site the unit to minimise “dead leg” distances, especially to the point of most frequent use.

Outlets above the unvented cylinder will reduce the outlet pressure available by 0.1 bar for every 1m of height difference. The unit should be protected from frost. Particular care is needed if siting in a garage or outbuilding. All exposed pipework should be insulated. The unvented cylinder must be installed VERTICALLY on a flat base capable of supporting the weight of the cylinder when full.

The minimum recommended cupboard size is 650mm wide by 750 deep.

You **MUST** take appropriate consideration of future access issues for maintenance of the cylinder and it’s associated components. Consideration should be given to position of discharge pipes (tundish), drain valves - shall be positioned away from electrical components.

The immersion heaters are 410mm long and care should be taken to ensure that they can be withdrawn for servicing if required. The discharge pipework from the safety valves should fall continuously and terminate safely..

INSTALLATION INSTRUCTIONS

SCHEMATIC DIAGRAM

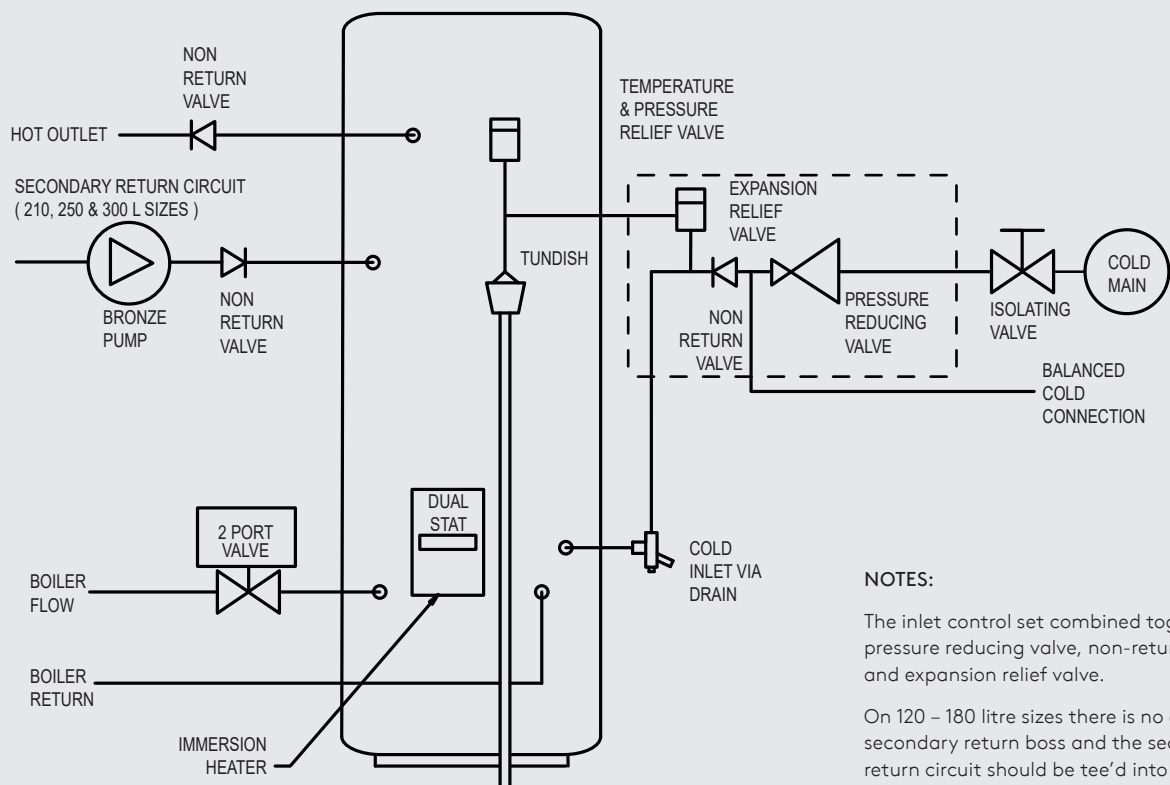

NOTES:

The inlet control set combined together a pressure reducing valve, non-return valve and expansion relief valve.

On 120 – 180 litre sizes there is no dedicated secondary return boss and the secondary return circuit should be tee'd into the cold feed pipe just above the drain elbow.

COLD MAINS PIPEWORK

Run the cold main through the building to the place where the unvented cylinder is to be installed. Take care not to run the cold pipe near hot water or heating pipework so that the heat pick-up is minimized. Identify the cold water supply pipe and fit an isolating valve (not supplied).

A 22mm BS1010 stopcock can typically be used but a 22mm quarter turn full bore valve would be better as it does not restrict the flow as much. Do not use “screwdriver slot” or

similar valves. Make the connection to the cold feed of the cylinder and incorporate a drain valve. Position the drain valve no higher than the cold inlet to ensure sufficient draining of cylinder when required. Position the inlet control just ABOVE the Temperature & Pressure Relief Valve (TPRV) mounted on the side of the cylinder. This ensures that the cylinder does not have to be drained down in order to service the inlet control set. Ensure that the arrow points in the direction of the water flow.

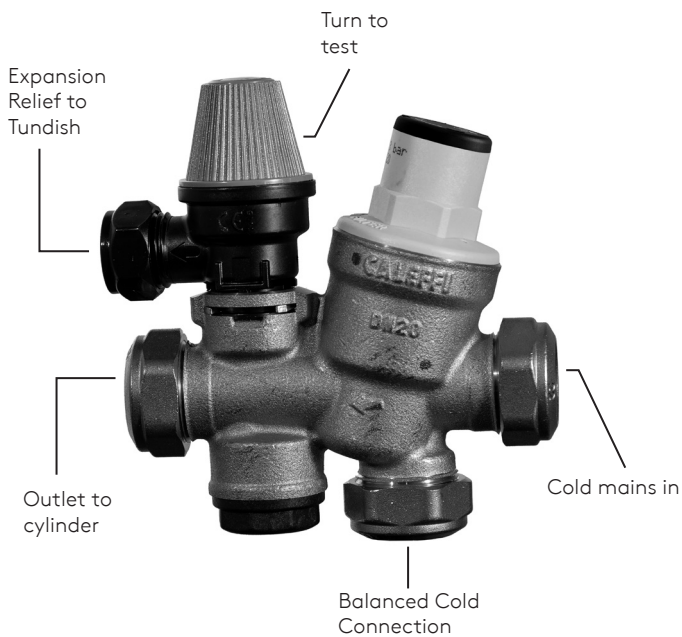

CONNECTING TO THE CYLINDER

All of the pipework connections on the cylinder are designed to accept 22mm copper pipe. The thread is $\frac{3}{4}$ " BSP male parallel thread. Suitable nuts and olives are provided.

Cut the tube with a pipe cutter and ensure no sharp edges or burrs protrude. Slide both gland nut and olive onto the tube and push tube fully home into the connection, ensuring the tube end fully bottoms on the connection recess. Smear the outer wall of the olive with plumbing paste and tighten gland nut in the prescribed manner. Upon filling/commissioning, ensure all connections are completely watertight. Note: No control or isolation valve should be fitted between the expansion relief valve and the storage cylinder. The relief valve connections should not be used for any other purpose.

BALANCED COLD CONNECTION

If there are to be showers, bidets or monobloc taps in the installation then a balanced cold supply is necessary. There is a 22mm balanced connection on the inlet set.

HOT WATER PIPEWORK

Run the first part of the hot water distribution pipework in 22mm. This can be reduced to 15mm and 10mm as appropriate for the type of tap etc. Your aim should be to reduce the volume of the hot draw-off pipework to a practical minimum so that the time taken for the hot water is as quick as possible.

A non-return valve is provided to prevent back-pressure from the cold water entering the cylinder via the hot water outlet. Failure to fit the non-return valve provided in accordance with the below instructions may result in guarantee claims being refused.

The non-return valve **MUST** be located in the same space as the unvented cylinder and be clearly visible. It should be

fitted in the pipework immediately after the hot water outlet from the cylinder. If an elbow is required immediately after the hot water outlet boss, then the non-return valve may be fitted in the first available straight section of the pipe after the elbow, providing this is within the cylinder cupboard and visible.

The non-return valve body includes 2 compression fittings, one at each end, to enable the valve to be connected into standard 22mm pipework. Cut a short length of 22mm copper pipe (e.g. 75-100mm to suit your installation) to fit between the hot water outlet boss on the cylinder or the elbow and the upstream side of the non-return valve.

IMPORTANT: You MUST ensure the non-return valve is connected in the correct orientation, with the arrow in the direction of flow of the water i.e. pointing away from the cylinder. Connect the downstream side of the non-return valve to the rest of the hot water system using 22mm copper pipe. Tighten connections and check for leaks after the system is pressurized.

Where monobloc mixing taps and showers are used, these should be installed to comply with the Water Supply (Water Fittings) Regulations 1999. If these devices are supplied with un-balanced supplies there should be single check valves installed at both inlets, to stop over pressurising of either supply.

PRIMARY COIL CONNECTIONS FOR INDIRECT UNITS

For Solar input models refer to pages 8-9 before making any connections.

Connect the primary connections (Indirect only) using the compression connections provided. The primary circuit must be positively pumped. Gravity circulation is not suitable. Either primary connection may be used as the primary flow, reheat times are not effected. The primary circuit can be open vented or sealed, with up to a maximum pressure of 3.5 bar and maximum flow temp of 85°C. If you seal the primary circuit an additional expansion vessel and safety valve is required. The boiler may be Gas, Electric or Oil but must be under effective thermostatic control. Uncontrolled heat sources such as some AGA's, back boilers, solid fuel stoves, etc. are NOT SUITABLE. Please contact our Technical department for guidance. Connect the two port zone valve (indirect only) into the primary flow pipework.

After commissioning and checking pipe connections insulate all pipework with pipe insulation material. Insulate discharge pipework and temperature and pressure relief valve ensuring access to the release knob and view of tundish is not blocked.

SECONDARY CIRCULATION

The unvented cylinder can be used with secondary circulation. An appropriate WRAS approved bronze circulator should be used in conjunction with a non-return valve to prevent backflow.

On large secondary circulation systems it may be necessary to incorporate an extra expansion vessel into the circuit to accommodate the increased system water volume. Secondary circulation should be avoided on Direct electrically heated units being used on off-peak electricity tariffs.

A secondary return boss is fitted as standard on 210, 250 & 300 ltr units. On smaller sizes, tee into the cold feed pipe above the drain.

IMMERSION HEATERS

The immersion heater is supplied with remotely mounted thermostat within the heater enclosure. The thermostat switches both live and neutral and comprises an adjustable control and a high limit manually resettable thermal cut-out. All thermostat connections and probe mounts are factory fitted.

The electrical supply to each immersion heater must be fused at 13A via a double pole isolating switch to BS 60335. The cable must be 1.5mm² 3 core heat resistant (85°C HOFR) sheathed flex complying to BS EN 50525-1.

Do not operate the immersion heater/s until the unit is full of water. Do not operate the immersion heater/s if any sterilisation liquid is in the cylinder as this will cause premature failure. Each immersion heater must be earthed.

Remove the thermostat cover by removing the retaining screw, opening the cover and sliding it to the left to disengage from the retaining clamps.

Connect to the terminal block ensuring the outer sheath is clamped and the cables are secured without strain on any of the components or cables.

ELECTRICAL CONNECTIONS

Warning: This appliance must be earthed and all wiring should be completed by a competent electrician in accordance with the latest I.E.E wiring regulations

Complete the wiring – use the appropriate wiring diagrams on pages 11-13.

Stationary appliances not fitted with means for disconnection from the supply mains having a contact separation in all poles that provide full disconnection under overvoltage category III, the instructions state that means for disconnection must be incorporated in the fixed wiring in accordance with the wiring rules.

DISCHARGE ARRANGEMENT

You will need to position the inlet control group so that the discharge from both safety valves can be joined together via a 15mm tee (see diagram below). Connect the tundish and then connect and route the discharge pipe. Ensuring to position the tundish in the same compartment as the cylinder and so that any discharge is visible.

Ensure all pipes to and from the tundish are cut square, are free from burrs or damage, and that the tundish is fitted vertically.

The discharge pipework must be routed in accordance with Part G3 of schedule 1 of the Building Regulations. The information that follows is not exhaustive and if you are in doubt you should seek advice.

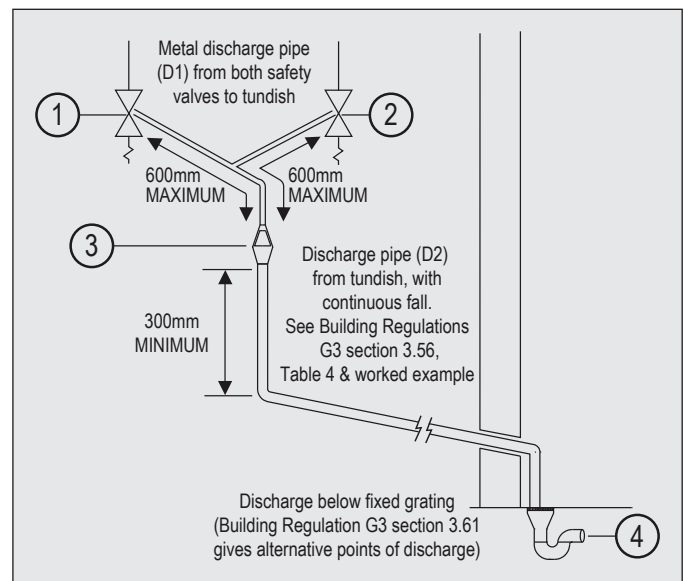

- 1) Expansion relief valve on inlet control set.
- 2) Temperature & pressure relief valve on cylinder.
- 3) Tundish.

Note: The discharge will consist of scalding water and steam. Asphalt, roofing felt and non-metallic rainwater goods may be damaged by such discharges.

Note: Although Building Regulations now permit the D2 pipe from the tundish to be installed in soil stacks within premises, we do not recommend this, as discharge from the temperature and pressure valve may continue for long periods of time. It is the installer's responsibility to ensure the discharge pipework can support the discharge for prolonged periods. If used, follow the guidance given in the G3 Building Regulations (mechanical seal without water trap). As discharge can be in excess of 90°C, discharge into plastic pipework is also not recommended.

The two safety valves will discharge water to indicate an issue with the plumbing & heating system, please refer to the trouble shooting guide page 17. When operating normally water will not be discharged. The tundish should be located in the same space as the unvented hot water storage system and be fitted as close as possible to, and lower than, the safety device, with no more than 600mm of pipe between the valve outlet and the tundish. The tundish should be positioned away from electrical devices.

The tundish should be located in a position so that any discharge is visible. In addition, where discharges from safety devices may not be apparent, extra consideration should be given, e.g. for people with impaired vision or mobility. This could be via the installation of a suitable electronically operated or other safety device to warn when discharge takes place.

The discharge pipe (D2) from the tundish should:

- A) Have a vertical section of pipe at least 300mm long, below the tundish before any elbows or bends in the pipework.
- B) Be installed with a continuous fall of at least 1 in 200 thereafter.

The discharge pipe (D2) from the tundish should be of metal or other material that has been demonstrated to be capable of withstanding temperatures of the water discharged.

The discharge pipe (D2) should be at least one pipe size larger than the nominal outlet size of the safety device, unless its total equivalent hydraulic resistance exceeds that of a straight pipe 9m long. Therefore, discharge pipes between 9m and 18m equivalent resistance length should be at least two sizes larger than the nominal outlet size of the safety device; between 18 and 27m at least three sizes larger. Bends must be taken into account in calculating the flow resistance. Refer to the diagram, Table 2 and the worked example.

An alternative approach for sizing discharge pipes would be to follow BS EN 806:2 specifications for design, installation, testing and maintenance of services supplying water for domestic use within buildings and their curtilages.

The discharge pipe (D2) should terminate in a safe place where there is no risk to persons in the vicinity of the discharge. Examples of acceptable discharge arrangements are:

- A) To a trapped gully with the end of the pipe below the fixed grating and above the water seal.
- B) Downward discharges at a low level; i.e. up to 100mm above external surfaces such as car parks, hard standings, grassed areas etc. are acceptable, providing that – where children play or otherwise could come into contact

with discharges – a visible wire cage or similar guard is positioned to prevent contact.

- C) Discharges at a high level; e.g. into a metal hopper and metal down pipe with the end of the discharge pipe clearly visible; or onto a roof capable of withstanding high temperature discharges of water and 3m from any plastic guttering systems that would collect such discharges.
- D) Device to warn when discharge takes place.

Discharge worked example

The example below is for G1/2 temperature relief valve with a discharge pipe (D2) having four elbows and a length of 7m from the tundish to the point of discharge.

Maximum resistance allowed for a straight length of 22mm copper discharge pipe (D2) from a G1/2 temperature relief valve is: 9.0m.

Subtract the resistance for four 22mm elbows at 0.8m each = 3.2m.

Therefore the maximum permitted length equates to: 5.8m. 5.8m is less than the actual length of 7m, therefore calculate the next largest size.

Maximum resistance allowed for a straight length of 28mm pipe (D2) from a G1/2 temperature relief valve equates to: 14m.

As the actual length is 7m, a 28mm (D2) copper pipe will be satisfactory.

Table 2: Sizing of copper discharge pipe 'D2' for a temperature relief valve with a G1/2 outlet size (as supplied).

Size of discharge pipework	Maximum length of straight pipe (no bends or elbows)	Deduct the figure below from the maximum length for each bend or elbow in the discharge pipe
22mm	Up to 9m	0.8m
28mm	Up to 18m	1.0m
35mm	Up to 27m	1.4m

PRODUCT CONNECTIONS RANGE TRIBUNE XE

DIRECT

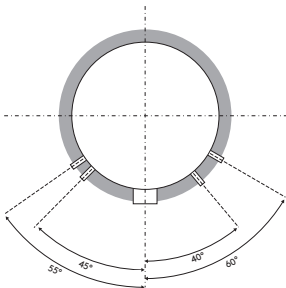
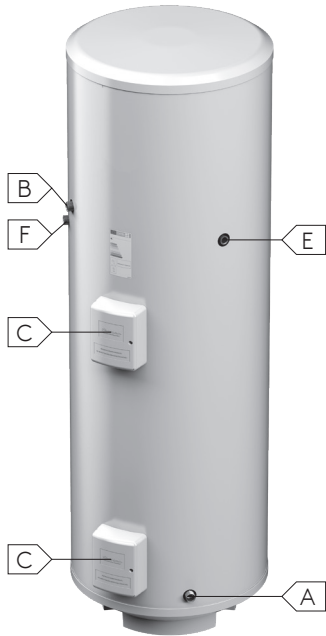

INDIRECT

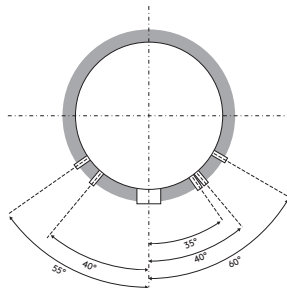
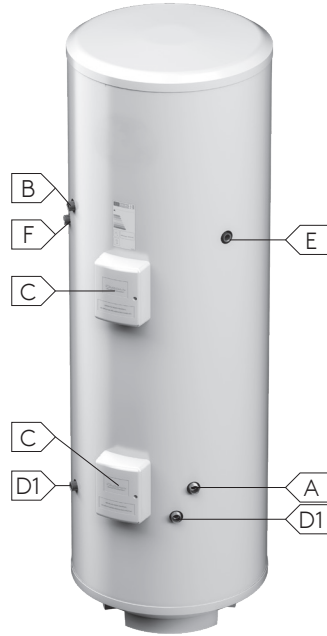

SOLAR INDIRECT

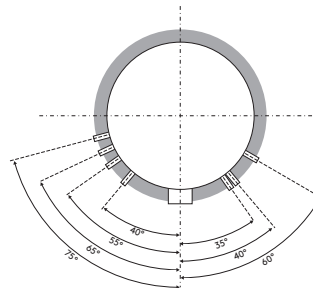
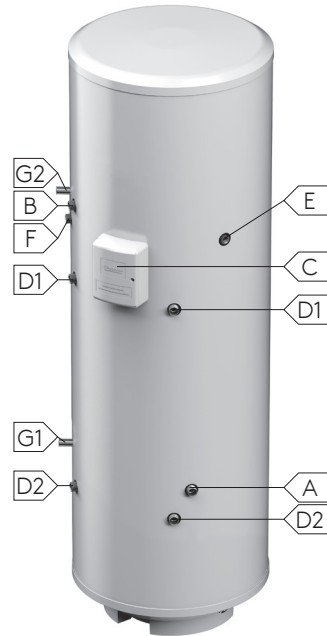

CYLINDER ONLY

A	22mm Cold feed
B	22m Hot water outlet
C	1¼" BSP - 3kW 14" Long titanium immersion heater (factory-fitted)
D1	22mm Compression connections - Boiler coil
D2	22mm Compression connections - Solar coil
E	¾" BSP union nut x 15mm (10bar / 90°C) Temperature & pressure relief valve (factory-fitted)
F	22mm Compression connections secondary return (210L, 250L & 300L only)
G1	Dry stat pocket (solar)
G2	Dry stat pocket (high limit)

INDIRECT / SYSTEM FIT

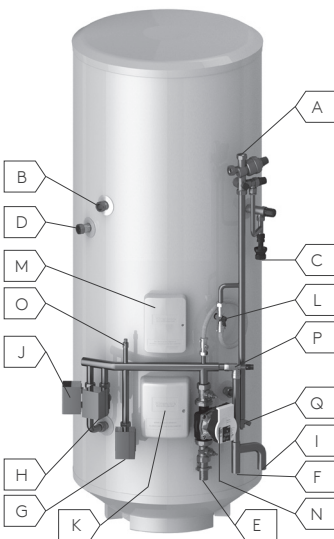

SOLAR INDIRECT

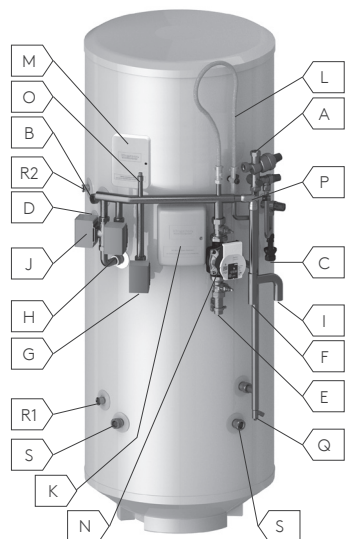

PRE-PLUMBED CYLINDER

A	22mm Inlet control set - cold feed
B	22mm Hot water draw-off
C	22mm Tundish drain off
D	22mm Secondary return (210L, 250L & 300L only)
E	28mm Flow from boiler
F	28mm Return to boiler
G	22mm Central heating flow - two port valve
H	22mm Central heating flow - two port valve (Twin zone only)
I	28mm Central heating return
J	DHW two port valve

K	Immersion heater & dual thermostats
L	Filling loop flexible hose
M	Wiring centre
N	Circulating pump (Not on system-fit models)
O	Manual bottle air eliminator
P	Auto bypass valve
Q	Cold feed drain
R1	Dry Stat pocket - Solar
R2	Dry Stat pocket - High limit
S	22mm Solar coil connections

PRODUCT CONNECTIONS ALBION ULTRASTEEL⁺

DIRECT

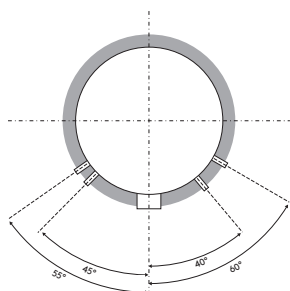
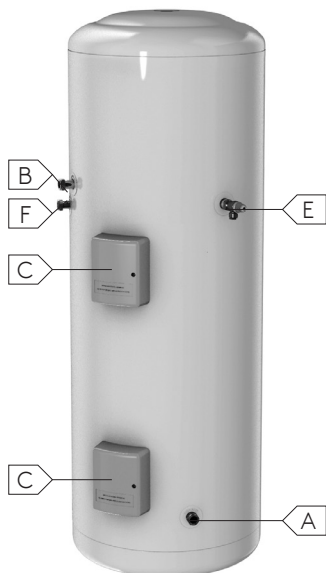

INDIRECT

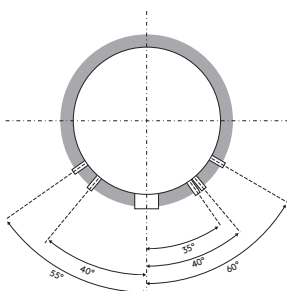
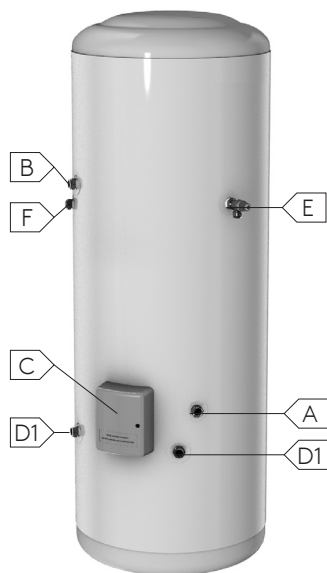

SOLAR INDIRECT

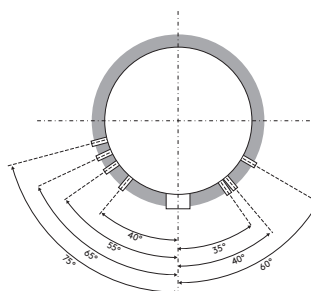
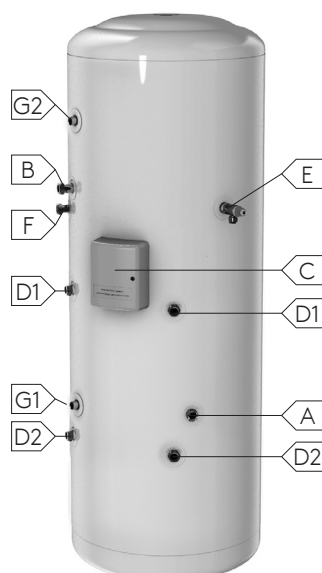

CYLINDER ONLY

A	22mm Cold feed
B	22m Hot water outlet
C	1¼" BSP - 3kW 14" Long titanium immersion heater (factory-fitted)
D1	22mm Compression connections - Boiler coil
D2	22mm Compression connections - Solar coil
E	¾" BSP union nut x 15mm (10bar /90°C) Temperature & pressure relief valve (factory-fitted)
F	22mm Compression connections secondary return (210L, 250L & 300L only)
G1	Dry stat pocket (solar)
G2	Dry stat pocket (high limit)

PRE-PLUMBED FIRST FIX PIPEWORK POSITION

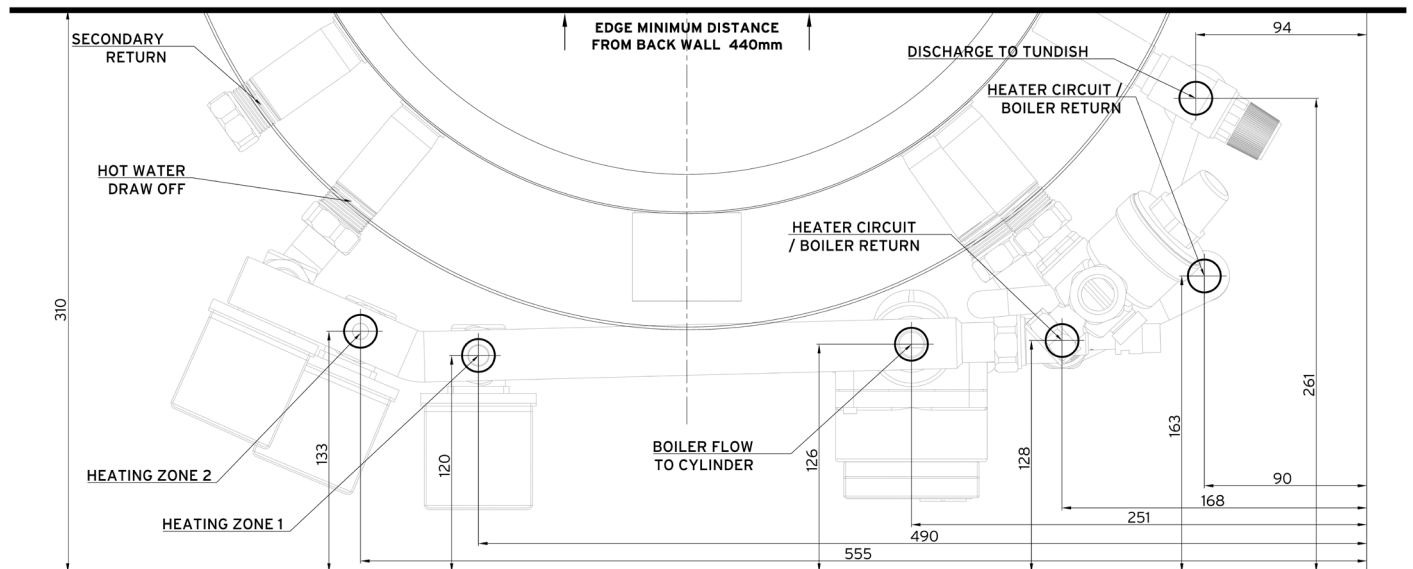

PRODUCT TECHNICAL SPECIFICATION

Maximum Inlet Water Pressure	12 Bar 1. 2MPa
Operating Pressure	3.0 Bar
Expansion Valve Opening Pressure & Maximum design pressure	8.0 Bar
Opening Pressure of T & P Valve	10.0 Bar
Opening Temperature of T & P Valve	90°C
Maximum Pressure on Primary Circuit (Indirect & Solar Coil)	3.5 Bar
Maximum operating temperature of the heating fluid	80°C
Minimum Inlet Pressure	1 Bar 100 KPa
Element Rating	3kW @ 240 V
Fuse Requirement	13A via Double Pole Switch
High Limit Thermostat for Element - Temperature Set Point	85°C

SOLAR HIGH LIMIT CONTROL TYPICAL SCHEMATIC WIRING DIAGRAMS

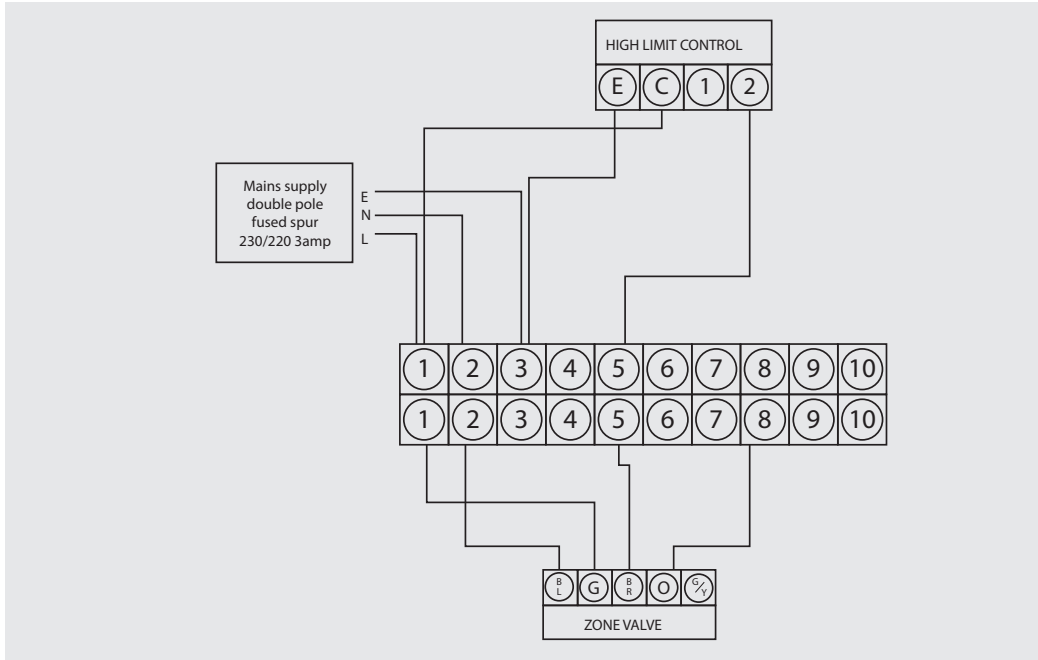

These schematic wiring diagrams depict an IMIT high limit control stat and the connections are numbered accordingly. Where an alternative is supplied connect as per manufacturer's instructions.

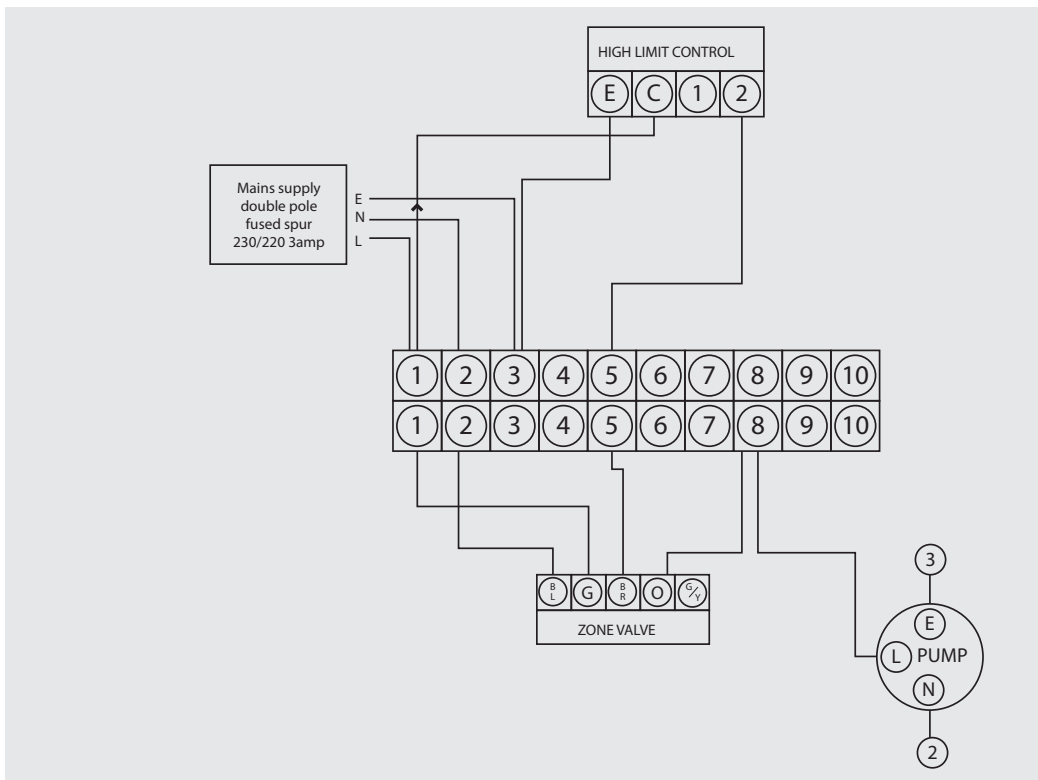

TYPICAL SCHEMATIC WIRING DIAGRAMS

The diagrams shown relate to the components listed. Other components and other manufacturers' components may vary in their wiring requirements, particularly thermostats. Always refer to manufacturers' instructions which may override the detail in order to function correctly.

VARIANT DUAL THERMOSTAT WIRING WIRING DIAGRAM 2 x TWO PORT ZONE VALVES (S-PLAN)

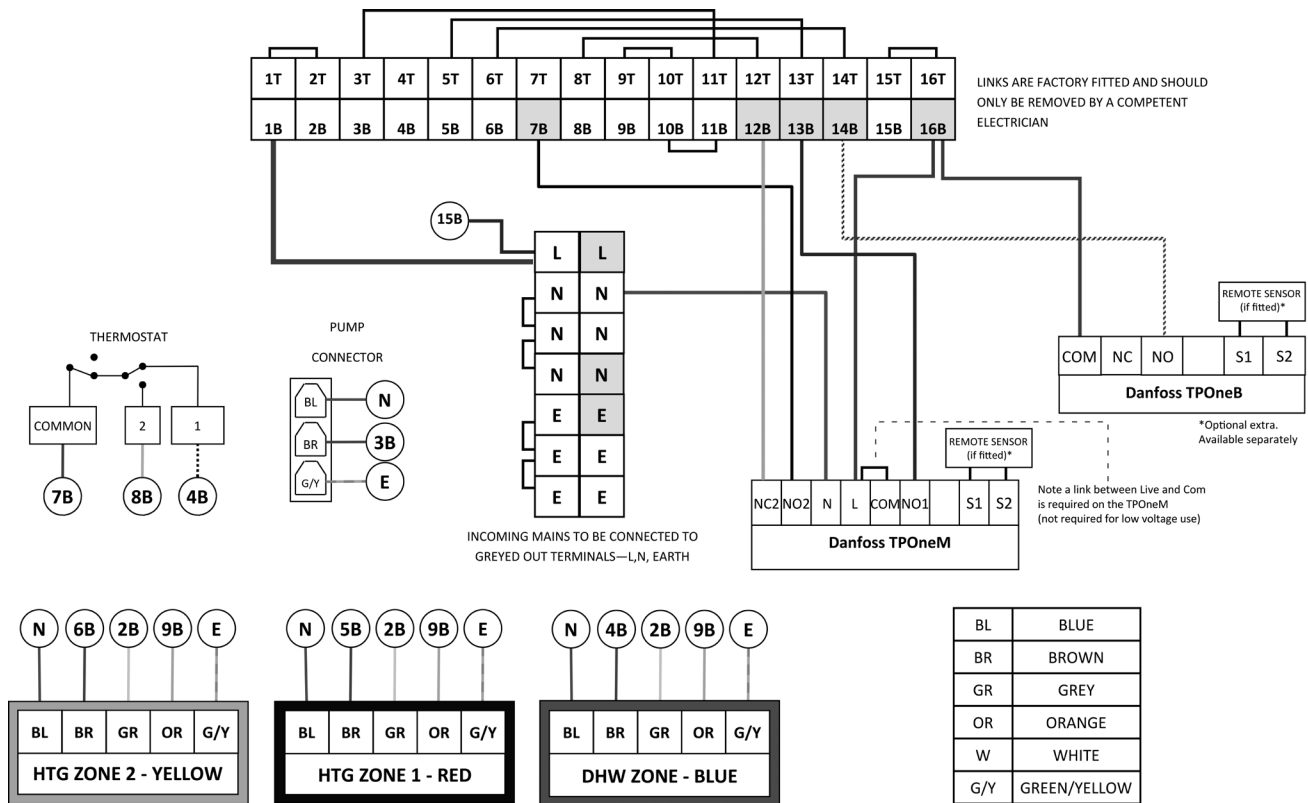

IF FITTED

TWIN HEATING ZONE WIRING DIAGRAM

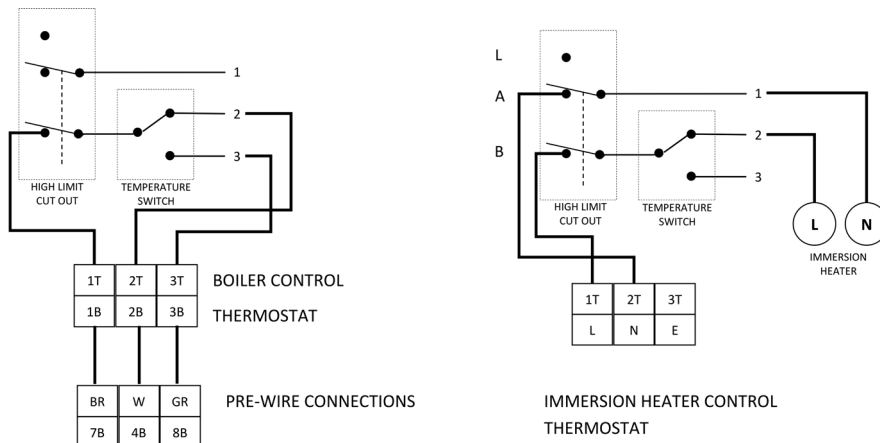

TITANIUM IMMERSION HEATER 1¼" BSP

One-piece Titanium Immersion has a 1¼" BSP thread, integral in the head of the unit. A standard 55mm box spanner can be used for removal/replacement. No special immersion key is required.

Before commencing work to remove the immersion heater ensure the cylinder is fully drained of water see page 16. Ensure heating controls are turned off.

WARNING - DANGER OF ELECTRIC SHOCK! DO NOT remove thermostat enclosure without isolating the supply to the product. If in doubt do not continue and seek advice from a competent electrician.

1. Check immersion heater compatibility with the cylinder.
2. The new immersion is supplied with a new 'O'-ring. Do not re-use the old 'O'-ring. Check the 'O'-ring is seated in place correctly on the immersion and is free from damage or debris. Lubricate 'O'-ring with a suitable WRAS approved grease.
3. Open the heater enclosure cover by removing the retaining screw and sliding it to the left to disengage the retaining clamps. Disconnect the red, black and green/yellow wires from the terminal spades on the immersion. Remove the thermostat probes from the immersion by carefully pulling them until they are free from the pocket.
4. Remove the old immersion heater using 55mm box spanner and suitable tommy bar. If no suitable spanner is available, it will be necessary to remove the thermostat housing from the cylinder by unscrewing the 3 self-tapping screws, to allow side access to the immersion with a 'C' spanner or adjustable spanner. If no suitable tool is available, do not attempt to replace the immersion.
5. Fit the new immersion heater using the same tool as for removal.

The immersion should be firmly tightened.

Note: Sealing performance is not dependant on the tightening torque, however the immersion should never be loose. Overtightening will result in damage to the threads.

6. Re-fit the probes into the pocket in the same order as they were removed. Re-fit the wires to the spade terminals ensuring the green/yellow earth wire is fitted to the centre terminal.
7. Before re-fitting the front cover, re-fill the cylinder and check for leaks: If any leakage occurs investigate the cause and rectify before continuing.
8. Open a hot outlet and refill cylinder from mains. Allow water to flow out of outlet. Once a good flow is achieved, close outlet.

9. When cylinder reaches maximum available pressure, re-check for leaks.
10. Turn hot water programmer back on. Allow cylinder to heat up. Check water is hot and thermostats are operating.
11. Now at operating temperature, re-check for leaks. After confirming everything is operating correctly, the front cover can be replaced.
12. Replace the front cover ensuring the wires are routed to avoid any trapping. Re-fit and tighten front cover screw.

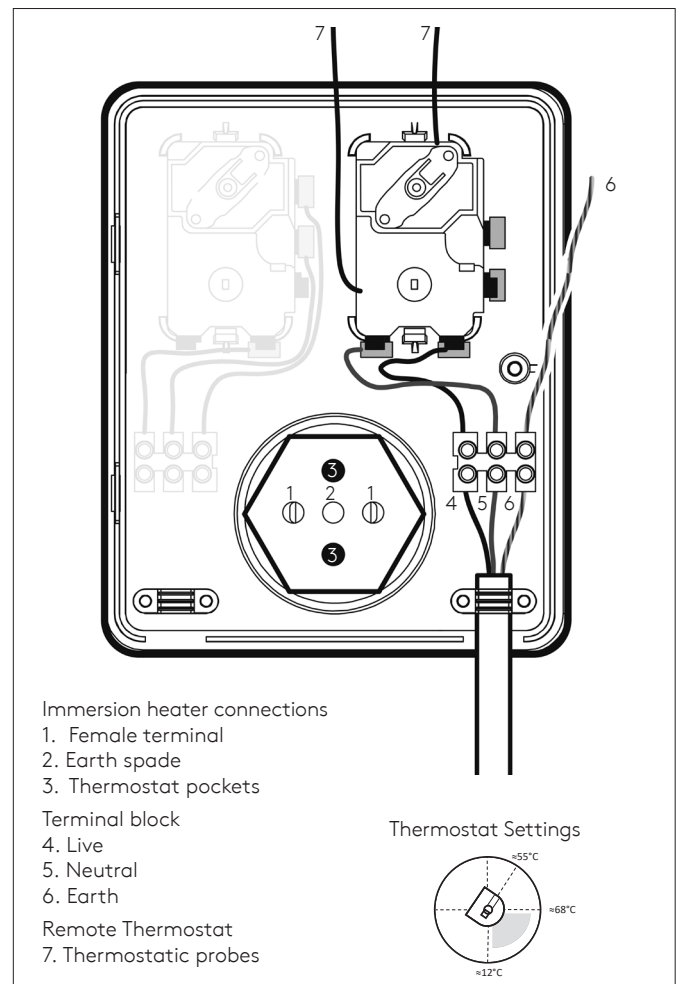

PRE-PLUMBED CYLINDER INSTALLATION

COLD MAINS PIPEWORK

Run the cold main through the building to the place where the unvented pre-plumbed unit is to be installed. Take care not to run the cold pipe near hot water or heating pipework so that the heat pick-up is minimized. Identify the cold water supply pipe and fit an isolating valve (not supplied). A 22mm BS1010 stopcock can typically be used but a 22mm quarter turn full bore valve would be better as it does not restrict the flow as much. Do not use "screwdriver slot" or similar valves. Make the connection to the inlet control set (Position 2). Ensure that the arrow points in the direction of the water flow.

CONNECTING TO THE CYLINDER

All of the pipework connections on the cylinder are suitable for 22mm copper pipe. The threads on connections are 3/4" BSP parallel male thread. Suitable nuts and olives are provided, in the Accessory pack. Only connect 22mm Table X copper tube to these connections. Cut the tube with a pipe cutter and ensure no sharp edges or burrs protrude. Slide both gland nut and olive onto the tube and push tube fully home into the connection, ensuring the tube end fully bottoms on the connection recess. Smear the outer wall of the olive with plumbing paste and tighten gland nut in the prescribed manner. Upon filling/commissioning, ensure all connections are completely watertight.

BALANCED COLD CONNECTION

If there are to be showers, bidets or monobloc taps in the installation then a balanced cold supply is necessary. There is a 22mm balanced connection on the inlet set.

HOT WATER PIPEWORK

Connect to HWDO (Position B on diagram). Run the first part of the hot water distribution pipework in 22mm. This can be reduced to 15mm and 10mm as appropriate for the type of tap etc. Your aim should be to reduce the volume of the hot draw-off pipework to a practical minimum so that the time taken for the hot water is as quick as possible. Where monobloc mixing taps and showers are used, these should be installed to comply with the Water Supply (Water Fittings) Regulations 1999. If these devices are supplied with un-balanced supplies there should be single check valves installed at both inlets, to stop over pressurising of either supply.

CONNECTIONS FOR INDIRECT UNITS

Connect to the boiler flow and return (Positions E & F) lines. An additional expansion vessel and safety valve is supplied. The boiler may be Gas, Electric or Oil but must be under effective thermostatic control. Uncontrolled heat sources such as some AGA's, back boilers, solid fuel stoves, etc. are NOT SUITABLE. Please contact our Technical department for guidance. Connect to (Position G) for the radiator circuits. Twin zone heating unit are supplied with 2 port zone valves in positions G and H.

CONNECTIONS FOR SOLAR COILS

Connect to the solar coil as detailed on pages 8 & 9 ensure the solar pump is connected via the over temperature cut out as described on page 8 & 9.

SECONDARY CIRCULATION

The unvented cylinder can be used with secondary circulation. An appropriate WRAS approved bronze circulator should be used in conjunction with a non-return valve to prevent backflow. On large secondary circulation systems it may be necessary to incorporate an extra expansion vessel into the circuit to accommodate the increased system water volume. A secondary return boss is fitted as standard on 210, 250 & 300 ltr units (Position F). On smaller sizes, tee into the cold feed pipe above the drain.

IMMERSION HEATERS

The immersion heater is supplied with remotely mounted thermostat within the heater enclosure. The thermostat switches both live and neutral and comprises an adjustable control and a high limit manually resettable thermal cut-out. All thermostat connections and probe mounts are factory fitted.

The electrical supply to each immersion heater must be fused at 13A via a double pole isolating switch to BS 3456. The cable must be 1.5mm² 3-core heat resistant (85°C HOFr) sheathed flex complying to BS 6141:1981 Table 8. Do not operate the immersion heater/s until the unit is full of water. Do not operate the immersion heater/s if any sterilisation liquid is in the cylinder as this will cause premature failure. Each immersion heater must be earthed.

Remove the thermostat cover by removing the retaining screw, opening the cover and sliding it to the left to disengage from the retaining clamps.

Connect to the terminal block ensuring the outer sheath is clamped and the cables are secured without strain on any of the components or cables.

ELECTRICAL CONNECTIONS

Warning: This appliance must be earthed and all wiring should be completed by a competent electrician in accordance with the latest I.E.E wiring regulations

Complete the wiring – use the appropriate wiring diagrams on page 11 - 13.

ELECTRICAL CONNECTIONS

Complete the wiring – use the appropriate wiring diagrams on pages 11 - 13.

COMMISSIONING

Carry out commissioning as per instructions on page 15 and in line with boiler manufacturer's instructions for the heating and the primary circuit. Primary pipework must be filled, bled and tested in accordance with the boiler manufacturer's instructions, to avoid damage to the circulation pump.

COMMISSIONING

FLUSHING & FILLING

Check all the connections for tightness including any factory made connections such as the immersion heater and the temperature and pressure relief valve. Before filling, open the hot tap furthest away from the unvented cylinder, to let air out. Open the cold main isolation valve and allow the unit to fill. When water flows from the tap allow it to run for a short while to flush through any dirt, swarf or flux residue. Close the tap and open every other hot tap in turn to purge all remaining air. Fill the system using mix of mains water and corrosion inhibitor. Follow inhibitor instructions for dosing levels.

DIRECT UNITS

After filling with water and after sterilisation liquid has been purged, switch on the power to the immersion heaters and allow the unit to start to heat. The immersion heater is supplied preset at 55°C. Turning fully to + sets to approx 65°C. Allow unit to heat up, adjust the thermostat so that the heater switches off at 60°C. Record information on commissioning check list (Page 19).

INDIRECT UNITS

Consult the boiler manufacturer's commissioning instructions and fill the primary circuit. Ensure the lever on the two port valve is set to the filling position. When full, move the lever back. Switch the programmer to Domestic Hot Water (DHW) and allow the unit to start to heat. Adjust the dial of the dual thermostat to between 55°C and 65°C as required. Allow unit to heat up, adjust the thermostat so that the heater switches off at 60°C. Record information on commissioning check list (Page 19).

STORAGE TEMPERATURE

The recommended storage temperature for both direct and indirect cylinders is 60-65°C. In hard water areas consideration should be given to reducing this to 50-55°C. In many healthcare applications the guidance on Legionella

control and safe water delivery temperatures will require storing the water at 60-65°C, distributing at 50- 55°C and using thermostatic mixing valves to control the final temperature. For details consult the NHS Estates Guidance on safe hot water temperatures.

SAFETY VALVE CHECKS

During heat-up there should have been no sign of water coming from either the expansion relief valve or the temperature/pressure relief valve. Now hold both of these safety valves fully open, allowing as much water as possible to flow through the tundish. Check that your discharge pipework is free from debris and is carrying the water away to waste efficiently. Release the valves and check that they reseal properly. On Completion of commissioning, fill in the Benchmark check list and leave with the house owner.

BENCHMARK SCHEME

The installer must follow the Benchmark code of practice for the Benchmark certification to be valid. The benchmark code of practice can be found on the internet using the following internet site www.centralheating.co.uk and follow links.

DECOMMISSIONING & DISPOSAL

Damage to the environment and risks to personal health are avoided by the proper decommissioning and disposal of this product.

To decommission your unvented hot water cylinder, isolate the electricity supply to the immersion heater and boiler/heat pump, before draining the cylinder and safely disconnecting all fixtures and fittings.

The cylinder is made from many recyclable materials; therefore we strongly encourage recycling of this product at your Local Authority recycling centre at the end of its working life. For more information on proper disposal, please contact your local council or waste disposal office.

HOMEOWNER / USER INSTRUCTIONS

This appliance can be used by children aged from 8 years and above and persons with reduced physical, sensory or mental capabilities or lack of experience and knowledge if they have been given supervision or instruction concerning use of the appliance in a safe way and understand the hazards involved. Children shall not play with the appliance. Cleaning and user maintenance shall not be made by children without supervision.

Your unvented cylinder should operate automatically in normal use, with only minimal input from your self as a user. To maintain the cylinder in good working order and ensure it

continues to operate efficiently and safely you **MUST** have it serviced every 12 months by a G3 qualified heating engineer. Failure to maintain the cylinder with annual servicing, including the completion of the Service Record, will void the cylinders guarantee.

To ensure the water in the cylinder remains hygienic the cylinder temperature is factory set to store the water at 65°C and we advise all users not to change this. It is intended that the hot water should be mixed with cold water at the outlet point such as a bath, basin, shower, or kitchen sink, down to a safe usable temperature to suit. Appropriate safety

considerations should be taken at the outlets such as the fitting of mixer valves/taps or thermostatic mixer valves/taps, especially in situations where there are vulnerable users.

Set up the user controls/programmers that have been installed with your cylinder to control when you would like to heat up the water by following the manufacturer's instructions. Note, most modern controls will include special holiday settings to ensure you don't waste energy when you are away.

RECHARGE THE EXPANSION SPACE

Important Note: All sealed heating systems will require re-pressurising from time to time, including systems with unvented cylinders. One indicator the system is ready for re-pressurising is water discharging through the tundish. When this happens with a Tribune Xe or Ultrasteel Plus cylinder just follow these simple steps:

YouTube video at:

<https://cylinders.kwe.kingspan.com/recharge>

or Scan the QR Code:



- Step 1: Turn off the boiler and immersion heaters to the cylinder.
- Step 2: Allow the water to cool through your normal usage. Alternatively run off all the hot water by opening the lowest hot tap in the property until the water runs cold. Once complete turn the tap off.
- Step 3: Turn off the water supply to the cylinder, via the stopcocks.
- Step 4: Open the lowest hot tap in the property.
- Step 5: With the hot tap open, turn the T&P valve on the cylinder anticlockwise by 45° and hold in this position until the gurgling noise stops and water stops running from the tap. Close the T&P valve.
- Step 6: Turn on the water supply to the cylinder, via the stopcock and when normal flow returns to the lowest tap, close the tap.
- Step 7: Turn the boiler and immersion heaters back on, and you're finished.

Depletion of the air gap is the most common reason for water discharging through the tundish and is there for the first cause that must be eliminated. However, should the problem persist, it could be an indication of other issues such as the cylinder overheating, due to a faulty thermostat or zone valve. IF WATER DISCHARGE THROUGH THE TUNDISH CONTINUES THIS INDICATES A FAULT CONDITION AND ACTION IS NEEDED. If this water is hot, turn the boiler and / or the immersion heater off. Do not turn off the water until the discharge runs cool. The discharge may also stop. CALL OUT A COMPETENT PLUMBER TO SERVICE THE UNIT. Tell them you have a fault on an unvented cylinder.

At the end of cylinder's operational life, make sure it is decommissioned and disposed of correctly; see page 15 for more details.

SERVICING

GENERAL

Servicing should only be carried out by competent installers and only spare parts approved by the manufacture may be used. NEVER bypass any safety devices or operate the unit without them being fully operational.

DRAINING

To drain down the cylinder, isolate from any heat sources including boilers, solar systems and the immersion heaters from the electrical supply. Isolate the cylinder from the cold mains water supply. Connect hose to the drain cock and secure with jubilee clip. Run hose to drain point lower than the cylinder, open the drain cock, hold open the T&P valve on the cylinder and allow the cylinder to drain. The cold feed dip pipe enables full draining of the cylinder. WARNING: WATER DRAINED OFF MAY BE VERY HOT!

IMPORTANT: After draining the cylinder do not close the T&P valve until the cylinder has fully cooled, failure to follow this instruction may result in damage to the cylinder and will

invalidate the guarantee.

The installer must follow the Benchmark code of practice for the Benchmark certification to be valid. Please see page 18 for further details.

ANNUAL MAINTENANCE

The unvented cylinder requires an annual service in order to ensure safe working and optimum performance. It is essential that the following checks are performed by a competent installer on an annual basis.

Water may drip from the discharge pipe of the pressure-relief device and that this pipe must be left open to the atmosphere. The pressure-relief device is to be operated regularly to remove lime deposits and to verify that it is not blocked.

An annual service should include the following as a minimum:

1. Visually check the cylinder for any obvious defects.
Make suitable checks to assess that the appliance has been installed correctly.

2. Recharging of the expansion space, see above.
3. Check the T&PR and Expansion Valves are operating correctly. Water should be run through each valve for approximately 30 seconds to ensure that any loose scale build up, or debris is flushed through before re sealing.
4. Whilst checking the safety valve operation above, check that the tundish drains and discharges correctly, and there are no blockages. **WARNING: THE WATER DISCHARGED MAY BE VERY HOT!**
5. Cleaning of filter on inlet control set, checking the condition of any seals and replace if necessary.
6. Check that any external controls such as heating system programmer are operating correctly. Testing of thermostats to ensure they are functioning correctly.

7. Carry out a visual check of any electrical wiring associated with the cylinder, immersion heater and its controls, it must be repaired by a qualified person in order to avoid a hazard.
8. Test immersion heater for continuity and resistance.
9. Record temperature of hot water at outlet after 1 minute of flow
10. Complete Benchmark Service record

YOUR GUARANTEE MAY BE VOID WITHOUT PROOF OF ANNUAL SERVICING.

SPARE PARTS

A full range of spare parts is available from Kingspan.
Tel: 0345 260 0258.

FAULT FINDING

FAULT	POSSIBLE CAUSE	SOLUTION
Water escaping from the case	Compression fittings not sealing	Check/remake joint with sealing paste
Cold water at Hot taps	Direct - immersion heater not switched on or cutout has triggered	Check / reset
	Indirect - boiler not working	Check boiler - consult boiler manufacturers' instructions
	Indirect - motorised valve fault	Check plumbing / wiring to motorised valve
	Indirect - cutout in dual stat has operated	Reset and investigate cause
Water discharges from expansion relief valve	If continual - pressure reducing valve (part of inlet control set) may not be operating correctly	Check outlet pressure from inlet control set is no greater than 3.0 bar.
	If continual - expansion relief valve seat may be damaged	Remove cartridge - check seat and renew if necessary
	Unit it being back pressurised	With cylinder cold check pressure in cylinder. If this is the same as the incoming mains pressure then you are getting backfeed. Install a balanced cold supply (see page 6) Follow recharge steps on page 17
Water discharges from temperature &. pressure relief valve	Unit has overheated - thermal controls have failed	"Switch off power to boiler and immersion heaters. Leave water supply on. Wait until discharge stops. Isolate water supply and replace if faulty"
Milky / cloudy water	Oxygenated water	Water from any pressurised system will release oxygen bubbles when flowing. The bubbles will settle out.
No hot water flow	Cold main off	Check and open stopcock
	Strainer blocked in pressure reducing valve	Isolate water supply and clean
	Inlet control set may be fitted incorrectly	Check and refit as required
Noise during hot water draw-off -typically worse in the morning.	Loose airing cupboard pipework	Install extra clips
Hot or warm water from cold tap	If tap runs cold after a minute or so the pipe is picking up heat from heating pipework.	Insulate / re-route

BENCHMARK SCHEME

Benchmark places responsibilities on both manufacturers and installers. The purpose is to ensure that customers are provided with the correct equipment for their needs, that it is installed, commissioned and serviced in accordance with the manufacturer's instructions by competent persons and that it meets the requirements of the appropriate Building Regulations. The Benchmark Checklist can be used to demonstrate compliance with Building Regulations and should be provided to the customer for future reference.

Installers are required to carry out installation, commissioning and servicing work in accordance with the Benchmark Code of Practice which is available from the Heating and Hotwater Industry Council who manage and promote the Scheme. Visit www.centralheating.co.uk for more information.

The installer must follow the Benchmark code of practice for the Benchmark certification to be valid. The Benchmark code of practice can be found on the internet using the following internet site www.centralheating.co.uk and follow links.

Kingspan is a licensed member of the Benchmark Scheme which aims to improve the standards of installation and commissioning of domestic heating and hot water systems in the UK and to encourage regular servicing to optimise safety, efficiency and performance.

Benchmark is managed and promoted by the Heating and Hotwater Industry Council. For more information visit www.benchmark.org.uk.

Please ensure that the installer has fully completed the Benchmark Checklist on the inside back pages of the installation instructions supplied with the product and that you have signed it to say that you have received a full and clear explanation of its operation.

The installer is legally required to complete a commissioning checklist as a means of complying with the appropriate Building Regulations (England and Wales).

All installations must be notified to Local Area Building Control either directly or through a Competent Persons Scheme. A Building Regulations Compliance Certificate will then be issued to the customer who should, on receipt, write the Notification Number on the Benchmark Checklist. This product should be serviced regularly to optimise its safety, efficiency and performance. The service engineer should complete the relevant Service Record on the Benchmark Checklist after each service. The Benchmark Checklist will be required in the event of any guarantee.

GUARANTEE TERMS & CONDITIONS

This guarantee applies only to products & parts supplied by the unvented cylinder manufacturer and its associated brands.

The manufacturer guarantees that for a period of 2 years on the stainless steel inner vessel and 1 year on parts, from the date of commissioning, or legal completion if new build, that the products and associated components installed will conform to the manufacturer's specification and be free from defects in materials and workmanship, subject to the conditions set out below.

Please note: this guarantee excludes all pipework and connections, and excludes any ancillary equipment as may be connected to the product, i.e. descaling equipment, water softeners. The guarantee is extended to a total of 25 years for the stainless steel inner vessel and 2 years on parts in domestic properties.

This guarantee means that the manufacturer will take responsibility for the cost of guarantee repair of a product by a Service Engineer approved by the manufacturer, so that the product shall conform to the manufacturer's specification.

The manufacturer reserves the right, at its discretion, to replace a product or major component where it considers it to be beyond economical repair.

In the event of a breakdown during the guarantee period contact our customer service department.

Guarantee repair is free of charge to you for any parts and labour, providing all the guarantee conditions have been met.

Please read the following conditions before registering your product and before seeking any guarantee service support.

IMPORTANT: The manufacturer guarantee is subject to the homeowner registering with the Customer Service Department within 30 days of commissioning / occupation if new build to confirm:

- Product Make / Model
- Details of installation (can be found in Commissioning Checklist left by installer).

Please register the product online at <http://kingspancylinders.com/guarantee> or complete the registration card provided & return to: Kingspan Water & Energy, Service Department - Cylinder Registration, 180 Gilford Rd, Portadown, Craigavon, Northern Ireland, BT63 5LF.

If you do not register the product then guarantee will be limited to twelve months from the date of commissioning.

The product must be maintained by a competent person* within 12 months after commissioning, and thereafter at 12-monthly

intervals. As the manufacturer, we reserve the right to seek evidence of this maintenance to our reasonable satisfaction, before approving any guarantee servicing / repairs. This may include evidence of completed Service Record and service agreement / invoice.

Annual services are available from the Customer Service/ Technical Support team.

* A competent person representing a business, who has been adjudged by an accredited body (An example of which is BPEC) to be sufficiently competent to self-certify that its work complies with Document (G) Part 3 of the Building Regulations of England and Wales May include SEI registered installers and/or FAS trained plumbers who have completed the renewables technology module.

Any exchanged component will become the legal property of the manufacturer.

This guarantee is valid provided that:

- The product has been installed by a competent installer and as per the instructions contained in the installation manual and all relevant Codes of Practice and Regulations in force at the time of installation.
- Any disinfection has been carried out in accordance with BS 6700.
- The product has not been modified in any way.
- The system is fed from domestic mains water supply compliant with Water Regulations 2000 i.e. the water must not be supplied from a well or bore hole.
- The product has only been used for the storage of wholesome water (max. 250mg/l chloride); for hard water areas, the use of an electrolytic scale reducer is recommend.
- Any 3rd party labour charges associated with replacing the unit or any of its components have been authorised in advance by the Customer Service/ Technical Support team.
- The product has not been subjected to frost, nor has it been tampered with or been subjected to misuse or neglect.
- No factory fitted parts have been removed for unauthorised repair or replacement.
- The Benchmark™ Commissioning Checklist and Service Record included with this product installation manual have been completed.
- Regular maintenance has been carried out by a competent person in accordance with the requirements set out in the maintenance section of the installation manual.

GUARANTEE TERMS & CONDITIONS

- The owner or installer has registered the product with the manufacturer's customer service department within 30 days of commissioning/occupation (in new build). Failure to do so may result in a reduced guarantee period.
- Evidence of purchase and date of supply must be submitted upon making a claim.
- Only replacement parts authorised by the manufacturer have been used.
- If a defect arises and a valid claim is received within the guarantee period, at its option and to the extent permitted by law the manufacturer shall either:
 - 1) Repair the defect at no charge, using new or refurbished replacement parts or
 - 2) Exchange the product with a product that is new or which has been manufactured using new or serviceable used parts or
 - 3) Refund the purchase price or a reasonable proportion of the purchase price.

The manufacturer reserves the right to inspect the product at your home before proceeding with any guarantee repair or replacement.

Any valid guarantee claims or guarantee service does not extend the original guarantee period. Information on extended guarantee is available upon request.

The guarantee only applies to the property at which the product was originally installed and applies only to properties in the United Kingdom or Ireland. The guarantee is fully transferable from a change of legal ownership of the property.

EXCLUSIONS:

The manufacturer will not be liable for any fault or costs arising from incorrect installation, incorrect application, lack of regular maintenance or neglect, accidental damage, malicious damage, misuse, any alteration, tampering or repair carried by a non-competent person.

The guarantee does not cover:

- The product, if the factory fitted temperature and pressure relief valve has been tampered with or removed.
- Neither the distributor nor manufacturer shall be responsible for any consequential damage howsoever caused.
- The effects of scale build up or the effects of corrosion.
- Additional costs that result from inadequate access provision such as removal of walls, ceilings, doors, other equipment or damage to decorative finishes, such as tiles, skirting board,

door frames etc. Sufficient access is defined as enough space to reach all parts for servicing and maintenance up to and including the full removal and exchange of the cylinder.

- Any consequential losses caused by the failure or malfunction of the product.
- Faults and any associated costs arising from lack of power or water.
- Failure incurred by water contamination, air pollution and natural disasters.
- Installations outside the United Kingdom or Ireland.
- Any consequential loss, loss of profits, revenues or receipts howsoever arising from any non-conformity or defect affecting the product or from any delay in repair or replacement of the product.
- Any loss or damage caused by delay in conduct of services or supply of parts required to rectify the non-conformity or defect (provided the manufacturer will use all reasonable efforts to ensure services are performed on a timely basis).
- Cost of repair or replacement of any product consumables or decorative finishes, such as filters and casings.

This guarantee does not affect any legal rights you may have as a consumer under applicable national legislation governing your purchase of this product.

For installations, outside of the United Kingdom or Ireland, please contact the Customer Service department.

The manufacturer shall make final determination as to the validity of any guarantee claim, & shall be entitled to charge you all reasonable costs incurred in investigating the claim where no fault is found, or the guarantee claim is rejected in accordance with these conditions.

GUARANTEE REGISTRATION CARD

Please use the card below to register within 30 days of commissioning / occupation if new build or at <http://kingspancylinders.com/guarantee> to benefit from the extended 25-year guarantee. By completing this form, you consent to Kingspan holding and using those details for all purposes directly related to the administration and conduct of guarantee services. Apart from the necessary usage, your personal data will not be disclosed to third parties.



AFFIX
YOUR
STAMP
HERE

Kingspan Water & Energy
Service Department - Cylinder Registration
180 Gilford Rd,
Portadown,
Craigavon,
Northern Ireland,
BT63 5LF

GUARANTEE REGISTRATION CARD

Please register within 30 days of commissioning / occupation if new build at <http://kingspancylinders.com/guarantee> or use the card below to benefit from the extended 25-year guarantee. By completing this form, you consent to Kingspan Water & Energy holding and using those details for all purposes related to the administration and conduct of guarantee services.



Homeowner Name
(Mandatory)

Installation Address
(Mandatory)

Post code

Email Address:

Phone
Number:

IF YOU WOULD LIKE TO RECEIVE SPECIAL OFFERS ON KINGSPAN SERVICE DEALS AND OTHER KINGSPAN PRODUCTS PLEASE TICK THIS BOX:

Make of Product

Model/Size

Serial Number
(Mandatory)

Installers Contact Details
(can be found in Commissioning Checklist)

Date of Installation
(can be found in Commissioning Checklist)

Signature of Homeowner

Date

Or Signature of Developer
(if new build)

Date