

Insulated Panels
UK & Ireland



QuadCore® Topdek Roof Panel Product Data Sheet

POWERED BY
QuadCore
TECHNOLOGY



Product Data

Applications

QuadCore® Topdek Roof Panel is a single component, factory pre-engineered insulated roof deck, comprising a high performance single-ply PVC membrane with insulation and a trapezoidal steel deck, which is suitable for flat and pitched roofs above 1:80 (0.72°) after deflection. It is also suitable for curved roof applications with a convex curve (45 m radius) and concave curve (50 m radius).



Available Lengths

Standard Lengths	1.8 m - 14.5 m
Longer Lengths (non-standard)	14.5 m - 16 m
Shorter Lengths (non-standard)	Below 1.8 m

Note: Additional costs and transport restrictions may apply for non-standard lengths. All lengths may change for export (outside of the UK and Ireland).

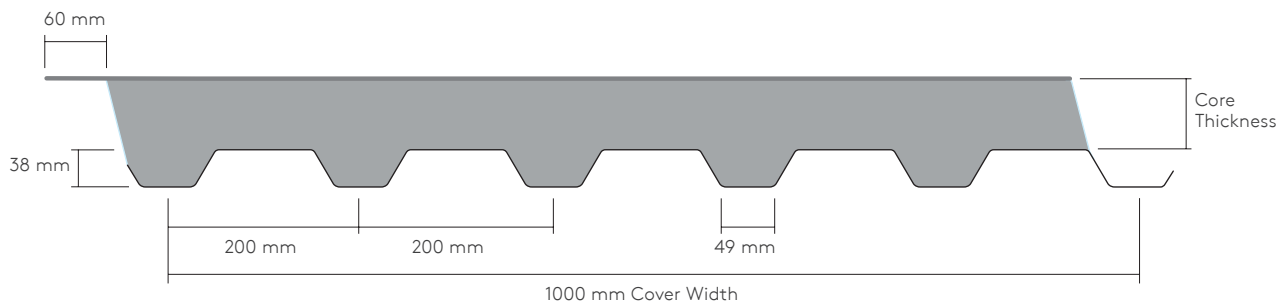

Dimensions, Weight and Thermal Performance

Core Thickness (mm)	34	71	91	100	120	140	160
Overall Thickness (mm)	72	109	129	138	158	178	198
U-value (W/m²K)	0.43	0.23	0.19	0.17	0.14	0.12	0.11
Weight (kg/m²)	8.9	10.3	11.1	11.4	12.2	12.9	13.7

The QuadCore® insulation used in QuadCore® Topdek Roof Panel has a Thermal Conductivity (λ) of 0.018 W/m.K

QuadCore® Topdek Roof Panels have a Thermal Transmittance (U-Value), calculated using the method required by the Building Regulations Part L2 (England & Wales), Building Standards Section 6 (Scotland), Part L (Republic of Ireland) and Part F2 (Northern Ireland).

Insulation Core

QuadCore® Topdek Roof Panels are manufactured with an HCFC, CFC and HFC free QuadCore® insulation core.



Product Data

Certification and Testing

Roof Applications

QuadCore® Topdek Roof Panels are tested to:

- BROOF(t4) to BS EN 13501-5: 2016 under the certified name KS1000TD when using Sikaplan SGK PVC membrane. This classification is valid for panel thicknesses from 34 – 160 mm and all roof pitches.
- BROOF(t4) to BS EN 13501-5: 2016 under the certified name KS1000TD when using Armourplan TD PVC membrane. This classification is valid for panel thicknesses from 34 – 160 mm and all roof pitches.

Fire Resistance

Fire resistance classifications are subject to panel thickness, method of assembly, membrane type and steel coating. Please contact Kingspan Tech-eXchange for project specific details.

Insurer Approvals

QuadCore® Topdek Roof Panels are tested to:

- FM 4471 approval standard for class 1 roof panels under the certified name QuadCore® Topdek KS1000TD when using Sikaplan SGK PVC membrane. This classification is valid for panel thicknesses 71 - 160 mm
- FM 4471 approval standard for class 1 roof panels under the certified name QuadCore® Topdek KS1000TDAR when using Armourplan TD PVC membrane. This classification is valid for panel thicknesses 71 - 160 mm.

Insurer approvals are large scale testing regimes that provide objective third-party testing, which is underpinned by quarterly, bi-annual and annual factory surveillance audits (depending on the region) to verify compliance. Insurer approvals are subject to panel thickness, cover width, orientation, method of assembly, steel coating and manufacturing facility. Please contact Kingspan Tech-eXchange for further information.



Environmental

Kingspan Insulated Panels produced in the UK and Ireland are certified to BES 6001 (Framework Standard for the Responsible Sourcing of Construction Products) 'Good'. QuadCore® insulated panel systems have Environmental Product Declarations in accordance with the requirements of EN 15804 + A2: 2019.

In addition, facilities located in Kingscourt, Holywell and Sherburn generate renewable energy onsite which contributes to that sites energy mix.

Recycled content calculations are available for all QuadCore® products via technical services. Kingspan insulated panels can directly contribute to BREEAM® / LEED® credits.

Air Leakage

An air leakage rate of 3m³/hr/m² at 50Pa or less can be achieved when using Kingspan insulated roof and wall panels.

For information on detailing required to achieve lower air leakage rates please contact Kingspan Tech-eXchange.

Acoustic

Sound Reduction Index (SRI)

Frequency (Hz)	125	250	500	1000	2000	4000
SRI (dB)	18	18	17	23	30	40

QuadCore® Topdek Roof Panel has a single figure weighted sound reduction $R_w = 23$ dB. Results are based on panels of similar profile and core material.

Materials

Substrate

External weather sheet – Reinforced Polyvinyl chloride (PVC) weatherproofing membrane.

Internal liner sheet - Metallic protected steel to BS EN 10346: 2015.

Please contact Kingspan Tech-eXchange for information on other substrates.

Coatings – External Weather Sheet

- Sikaplan SGK: Multi-layer synthetic PVC roof waterproofing membrane with an inlay of glass non-woven and polyester fleece backing.
- Armourplan TD: Glass tissue reinforced polyester fleece back PVC membrane.

Coatings – Internal Liner Sheet

- Kingspan CLEANsafe 15: The coating has been developed for use as the internal lining of insulated panels. Standard colour is “bright white” with an easily cleaned surface.

For information on alternative coating options please contact Kingspan Tech-eXchange.

Product Data

Panel End Cut Back

Panel end lap left handed (liner sheet)	60 mm
Panel end lap right handed (liner sheet)	60 mm

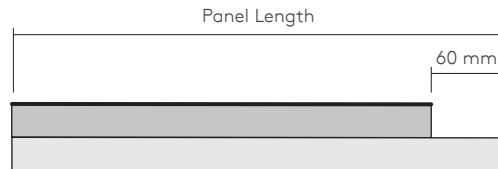

Product Tolerance

Cut to Length (< 3 m)	± 5 mm
Cut to Length (> 3 m)	± 10 mm
Cover Width	± 3 mm
Thickness (Core ≤ 100 mm)	± 2 mm
Thickness (Core > 100 mm)	± 2%
End Square	± 3 mm

Handing

QuadCore® Topdek Roof Panel can be manufactured in both left to right handed (LH) and right to left handed (RH).

Quality & Durability

QuadCore® Topdek Roof Panels are manufactured from the highest quality materials, using state of the art production equipment to rigorous quality control standards, complying with BS EN ISO 9001 standard, ensuring long term reliability and service life. The panels are also being manufactured under Environmental Management System Certification BS EN ISO 14001, Energy Management System Certification BS EN ISO 50001 and Occupational Health and Safety Certification BS EN ISO 45001 and Compliance Management Systems BS EN ISO 37301.

Warranty

QuadCore® Assured Panel Warranty

- 25 years thermal performance
- 25 years fire performance
- 25 years structural performance
- 25 years environmental performance
- 15 years membrane performance, which can be increased up to 25 years on application

Packing

QuadCore® Topdek Roof Panels are stacked weather sheet to weather sheet (to minimise pack height). The top and sides are protected by either cardboard or polystyrene and spiral wrap stretch polyfilm. The number of panels in a pack will vary depending on thickness.

Core Thickness (mm)	34	71	91	100	120	140	160
No. of Panels per Pack	15	10	9	8	7	7	6

Note: Applies to UK pack sizes. Please contact Kingspan Tech-eXchange for export information.

Sea Freight

Fully timber crated packs are available on projects requiring delivery by sea freight shipping, at additional costs. Alternatively, steel containers can be used. Special loading charges apply.

Delivery

All deliveries (unless indicated otherwise) are by road transport to project site. Off-loading is the responsibility of the client.

Site Installation Procedure

Site assembly instructions are available from Kingspan Tech-eXchange.

Product Data

Load / Span Tables

External sheet membrane, internal sheet steel.

Load / span tables to be compared against calculated characteristic (i.e. unfactored) wind load values.

Single Span

Core Thickness (mm)	Load Type	Uniformly Distributed Loads kN/m ²											
		Span (m)											
		1.0	1.2	1.4	1.6	1.8	2.0	2.2	2.4	2.6	2.8	3.0	3.2
34	Pressure	6.60	4.56	2.93	1.93	1.33	0.95	0.69	0.51	0.38	0.29	0.22	0.17
	Suction	5.65	3.94	2.91	2.24	1.78	1.46	1.16	0.92	0.74	0.61	0.51	0.44
71	Pressure	6.58	4.54	2.91	1.92	1.32	0.93	0.68	0.50	0.37	0.28	0.21	0.15
	Suction	5.66	3.95	2.92	2.25	1.79	1.47	1.18	0.93	0.75	0.62	0.53	0.45
91	Pressure	6.58	4.54	2.90	1.91	1.31	0.92	0.67	0.49	0.36	0.27	0.20	0.14
	Suction	5.67	3.96	2.93	2.26	1.80	1.47	1.18	0.94	0.76	0.63	0.53	0.46
100	Pressure	6.57	4.53	2.90	1.91	1.31	0.92	0.66	0.49	0.36	0.26	0.19	0.14
	Suction	5.67	3.96	2.93	2.26	1.80	1.47	1.19	0.94	0.76	0.63	0.54	0.46
120	Pressure	6.57	4.53	2.89	1.90	1.30	0.91	0.66	0.48	0.35	0.26	0.19	0.13
	Suction	5.67	3.96	2.93	2.26	1.81	1.48	1.20	0.95	0.77	0.64	0.54	0.47
140	Pressure	6.56	4.52	2.89	1.89	1.29	0.91	0.65	0.47	0.34	0.25	0.18	0.13
	Suction	5.68	3.97	2.94	2.27	1.81	1.48	1.20	0.95	0.78	0.65	0.55	0.48
160	Pressure	6.55	4.51	2.88	1.88	1.28	0.90	0.64	0.46	0.34	0.24	0.17	0.12
	Suction	5.68	3.97	2.94	2.27	1.82	1.49	1.21	0.96	0.79	0.66	0.56	0.48

Double Span

Core Thickness (mm)	Load Type	Uniformly Distributed Loads kN/m ²											
		Span (m)											
		1.0	1.2	1.4	1.6	1.8	2.0	2.2	2.4	2.6	2.8	3.0	3.2
34	Pressure	4.00	2.97	2.28	1.81	1.47	1.21	1.01	0.86	0.73	0.63	0.54	0.47
	Suction	6.73	4.69	3.46	2.67	2.12	1.73	1.44	1.22	1.05	0.91	0.80	0.71
71	Pressure	4.79	3.48	2.63	2.06	1.64	1.31	1.06	0.88	0.74	0.62	0.53	0.46
	Suction	6.74	4.70	3.47	2.67	2.13	1.74	1.45	1.23	1.05	0.92	0.81	0.72
91	Pressure	5.11	3.68	2.76	2.09	1.63	1.30	1.06	0.87	0.73	0.62	0.52	0.45
	Suction	6.75	4.71	3.48	2.68	2.13	1.74	1.45	1.23	1.06	0.92	0.81	0.72
100	Pressure	5.23	3.75	2.75	2.08	1.63	1.30	1.05	0.87	0.73	0.61	0.52	0.45
	Suction	6.75	4.71	3.48	2.68	2.13	1.74	1.45	1.23	1.06	0.93	0.82	0.73
120	Pressure	5.46	3.78	2.75	2.08	1.62	1.29	1.05	0.86	0.72	0.61	0.51	0.44
	Suction	6.75	4.72	3.49	2.69	2.14	1.75	1.46	1.24	1.07	0.93	0.82	0.73
140	Pressure	5.48	3.77	2.74	2.07	1.61	1.28	1.04	0.86	0.71	0.60	0.51	0.43
	Suction	6.76	4.72	3.49	2.69	2.14	1.75	1.46	1.24	1.07	0.94	0.83	0.74
160	Pressure	5.47	3.76	2.73	2.06	1.61	1.28	1.03	0.85	0.71	0.59	0.50	0.43
	Suction	6.76	4.72	3.50	2.70	2.15	1.76	1.47	1.25	1.08	0.94	0.83	0.74

1 The following deflection limits have been used:

- Pressure loading $L/200$.
- Suction loading $L/150$.

2 All panel thicknesses have been calculated with a minimum support width of 50 mm. Larger support widths are possible.

3 The actual wind suction resisted by the panel is dependent upon the number of fasteners and the material of the supporting element.

4 The fastener calculation should be carried out in accordance with the appropriate standards.

5 For intermediate values linear interpolation may be used.

6 The allowable steelwork tolerance between bearing planes of adjacent supports is ± 5 mm.

Product Data

Load / Span Tables

External sheet membrane, internal sheet steel.

Load / span tables to be compared against calculated characteristic (i.e. unfactored) wind load values.

Triple Span

Core Thickness (mm)	Load Type	Uniformly Distributed Loads kN/m ²											
		Span (m)											
		1.0	1.2	1.4	1.6	1.8	2.0	2.2	2.4	2.6	2.8	3.0	3.2
34	Pressure	4.82	3.59	2.78	2.21	1.80	1.49	1.25	1.05	0.80	0.63	0.49	0.39
	Suction	8.40	5.85	4.32	3.32	2.63	2.14	1.78	1.51	1.29	1.08	0.89	0.75
71	Pressure	5.83	4.26	3.24	2.54	2.04	1.66	1.35	1.03	0.79	0.61	0.48	0.38
	Suction	8.41	5.86	4.32	3.33	2.64	2.15	1.79	1.52	1.30	1.09	0.90	0.76
91	Pressure	6.25	4.52	3.41	2.63	2.06	1.65	1.35	1.02	0.78	0.60	0.47	0.37
	Suction	8.42	5.87	4.33	3.33	2.65	2.16	1.80	1.52	1.31	1.10	0.91	0.77
100	Pressure	6.41	4.62	3.47	2.63	2.06	1.65	1.34	1.02	0.78	0.60	0.47	0.37
	Suction	8.42	5.87	4.33	3.33	2.65	2.16	1.80	1.52	1.31	1.10	0.92	0.77
120	Pressure	6.72	4.75	3.46	2.62	2.05	1.64	1.34	1.01	0.77	0.59	0.46	0.36
	Suction	8.42	5.87	4.34	3.34	2.65	2.17	1.80	1.53	1.31	1.11	0.92	0.78
140	Pressure	6.88	4.74	3.45	2.62	2.04	1.63	1.33	1.01	0.76	0.59	0.45	0.35
	Suction	8.43	5.88	4.34	3.34	2.66	2.17	1.81	1.53	1.32	1.11	0.93	0.79
160	Pressure	6.87	4.73	3.45	2.61	2.04	1.63	1.32	1.00	0.76	0.58	0.45	0.34
	Suction	8.43	5.88	4.35	3.35	2.66	2.18	1.81	1.54	1.32	1.12	0.94	0.80

- The following deflection limits have been used:
 - Pressure loading $L/200$.
 - Suction loading $L/150$.
- All panel thicknesses have been calculated with a minimum support width of 50 mm. Larger support widths are possible.
- The actual wind suction resisted by the panel is dependent upon the number of fasteners and the material of the supporting element.
- The fastener calculation should be carried out in accordance with the appropriate standards.
- For intermediate values linear interpolation may be used.
- The allowable steelwork tolerance between bearing planes of adjacent supports is ± 5 mm.

Contact Details

UK

Kingspan Limited

Greenfield Business Park No. 2
Greenfield | Holywell | Flintshire
North Wales | CH8 7GJ

T: +44 (0) 1352 716100

E: info@kingspanpanels.com

www.kingspanpanels.co.uk

Ireland

Kingspan Limited

Carrickmacross Road | Kingscourt
Co. Cavan | A82 E897

T: +353 (0) 42 96 98500

E: info.ire@kingspanpanels.com

www.kingspanpanels.ie



For the most up-to-date
version of this document
please scan or click [here](#).

For the product offering in other markets please contact your local sales representative or visit www.kingspanpanels.com

Care has been taken to ensure that the contents of this publication are accurate, but Kingspan Limited and its subsidiary companies do not accept responsibility for errors or for information that is found to be misleading. Suggestions for, or description of, the end use or application of products or methods of working are for information only and Kingspan Limited and its subsidiaries accept no liability in respect thereof.

